

NeuTorq Nutrunner

- **Intelligent system to ensure each fasten is accurately completed**
- **Less damage to the tool, socket and bolt assembly**
- **Quiet operation, fatigue-reduced and increased safety design**

- **Free running torque prediction and fastening torque detection**
- **Accuracy 5% • CmK >= 1.67**
- **Calibration certification according to the international standard**

Special Reaction Arm

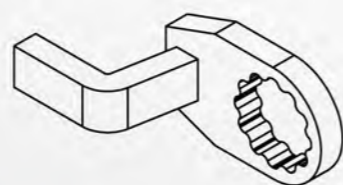
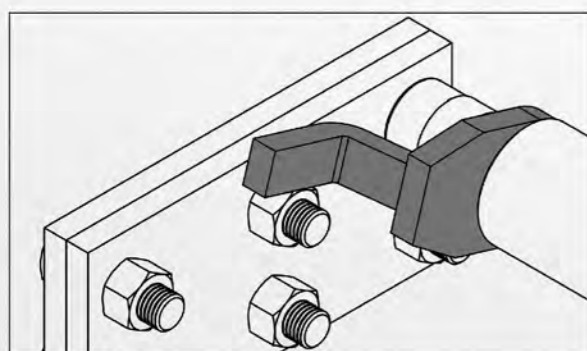
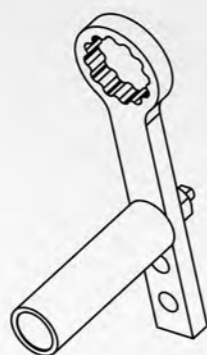
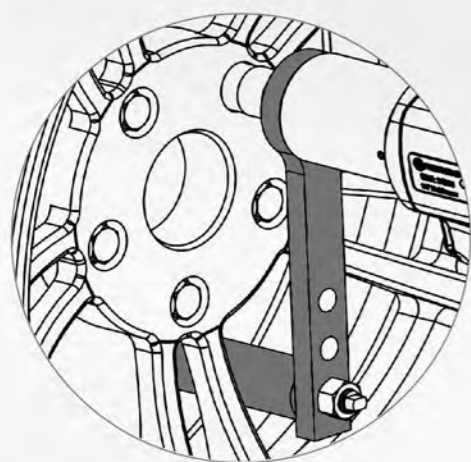

360° Swiveling

- **Swiveling front case for easy tool positioning**

Reaction Arm

- **Various arm for right application**

CPU Control Panel

- **Enable to see**
- **Target torque setting in free running**
- **Fastening torque**
- **Accept / Reject light**



New



Torque Control

- **Set target torque by applications**
- **Max. Torque : 270 Nm**

ECD Lever

- **Easy Change Direction**
- **Forward and Reverse**
- **Loosen by the maximum torque**



Feather Trigger

- **Slow starting for easy object contact**

Power saving design

- **AAA 1.5V x 3PC**

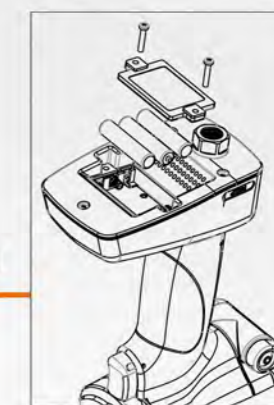

24090
PRECISE BOLTING TOOL
DIGITAL DISPLAY

Item No.	Speed RPM	Max. Torque Nm/ft-lb	Square Drive	Length mm/inch	Weight kg/lb	Air Consumption LPM / CFM	Vibration m/s ²	Noise Level LpA / LwA	Working Pressure Bar / PSI
24090	55	270 (200)	1/2"	228 (8.9)	3.2 (7.04)	132 (4.6)	< 2.5	95.5 / 106.5 DB	6.2 (90)

NeuTorq Tool Series

- **Intelligent system to ensure each fasten is accurately completed**
- **Less damage to the tool, socket and bolt assembly**
- **Quiet operation, fatigue-reduced and increased safety design**
- **Free running torque setting and fastening torque detection**
- **Accuracy 5% • CmK>=1.67**
- **Calibration certification according to the international standard**

Torque Controller

- Direct Drive
- 0.3 HP



D64301

1/4" Air Screwdriver

CPU control panel

- Target torque setting in free running
- Fastening torque
- Accept / Reject light
- Low Battery message



- Direct Drive
- 0.3 HP

D64300

1/4" Air Screwdriver



- Auto Shut off
- Swivel Exhaust

D65002T

1/4" Oil Pulse Screwdriver



Direct Drive

D64201

1/4" Air Screwdriver

Item No.	Speed RPM	Chuck mm/inch	Max. Torque Nm/in-lb	Length mm/inch	Weight kg/lb	Air Consumption LPM / CFM	Vibration m/s ²	Noise Level LpA / LwA	Working Pressure Bar / PSI
D64201	3,000	1/4" Hex	8.5 (75.2)	140 (5.5)	0.8 (1.9)	85 (3.0)	< 2.5	86 / 97 DB	6.2 (90)
D64300	2,300	1/4" Hex	4.5 (39.8)	210 (8.5)	0.8 (1.9)	113 (4.0)	< 2.5	81 / 92 DB	6.2 (90)
D64301	1,900	1/4" Hex	6.0 (53.1)	220 (8.6)	1.1 (2.4)	113 (4.0)	< 2.5	81 / 92 DB	6.2 (90)
D65002T	5,800	1/4" Hex	15.0 (132.7)	182 (7.17)	1.0 (2.3)	85 (3.0)	2.8	85 DB	6.2 (90)



NeuTorq Tool Series

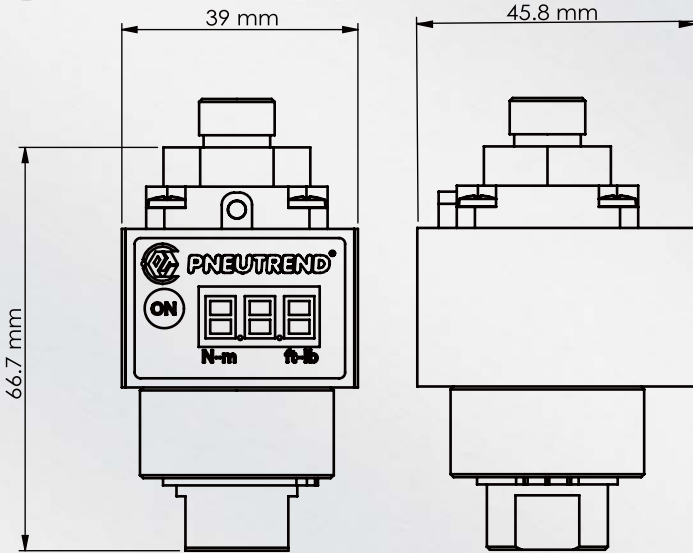

Torque Controller

CPU control panel

- Target torque setting in free running
- fastening torque
- Accept / Reject light
- Low Battery message



- Direct Drive
- 0.3 HP



D23000 3/8" Direct Drive Wrench

- Auto Shut off
- Swivel Exhaust



D25002T 3/8" Oil Pulse Wrench

Item No.	Speed RPM	Max. Torque Nm/in-lb	Square Drive	Length mm/inch	Weight kg/lb	Air Consumption LPM / CFM	Vibration m/s ²	Noise Level LpA / LwA	Working Pressure Bar / PSI
D23000	1900	6.0 (53.1)	3/8"	220 (8.6)	1.10 (2.4)	113 (4.0)	< 2.5	81 / 92 DB	6.2 (90)
D25002T	5800	15.0 (132.7)	3/8"	178 (7.0)	1.06 (2.3)	85 (3.0)	2.8	85 DB	6.2 (90)

Torque Calibration Analyser

- Suitable for hand torque wrenches and power tools
- Unit : ft-lb, Nm
- Mode : peak, track
- Power : 110 V ~ 240 V
- Working Temperature : - 20°C ~ 70°C



L-TCA0010E 1.0 ~ 10 Nm (0.7 ~ 7.4 ft-lb)

L-TCA0050E 5.0 ~ 50 Nm (3.7 ~ 36 ft-lb)



L-TCA0500E 50 ~ 500 Nm (36 ~ 369 ft-lb)